

Rezervoar je osnovni element svakog pogonskog agregata sa višestrukou ulogom: smeštaj radne tečnosti, odvođenje toplote, izdvajanje vazduha, taloženje nečistoće. Može poslužiti i za nošenje pogonskih i upravljačkih uređaja. Spada u grupu malih rezervoara a urađen je, odliven od lakog metala, sa rebrima za hlađenje i povećanje krutosti. Opremljen je nalivnim filtrom sa oduškom, pokazivačem max nivoa i čepom za ispuštanje ulja. Poklopac rezervoara je predviđen za skidanje radi obrade i montaže nosećih uređaja (pumpni agregat ili upravljački uređaj) a pričvršćen je vijcima.

Reservoir is basic element of hydraulic power unit. Although primarily functioning as a point of storage and supply for hydraulic system fluid, reservoir also assists in the separation of air and contaminants from the fluid and helps dissipate heat generated within the system. Frequently it is used as an integral part of the complete hydraulic power package, forming the base on which the el. motor/pump assembly, and associated valves are mounted. The reservoir is made of a light metal casting with ribs for better cooling and rigidity. It is provided with filling filter with breather, oil level gauge and drainage plug. A separate top cover fixed with bolts is foreseen to carry el. motor/pump assembly and control components.

TEHNIČKE KARAKTERISTIKE
TECHNICAL DATA

Oznaka Designation	6948749	6948723	6948715	6948707	6948799
Simbol Symbol					
Položaj ugradnje Mounting position	horizontalni horizontal				
Nazivna zapremina (l) Nominal volume (l)	10	16	25	40	63
Korisna zapremina (l) Effective volume (l)	8	14	20	38	60
Masa (kg) Mass (kg)					

UGRADNI CRTEŽ (mere u mm)
MOUNTING DRAWING (dimensions in mm)

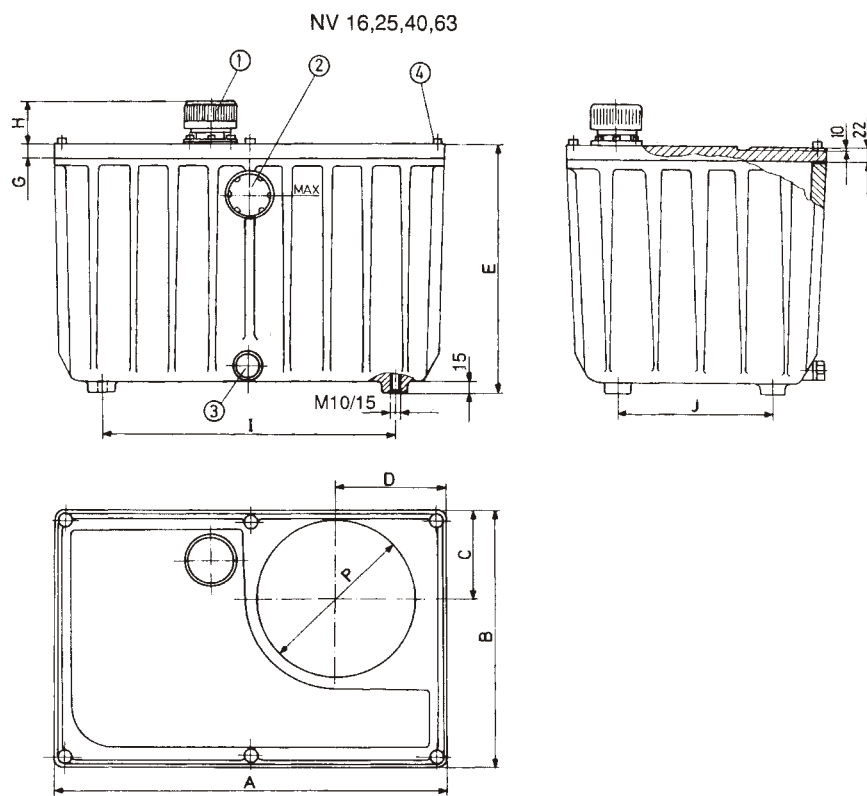
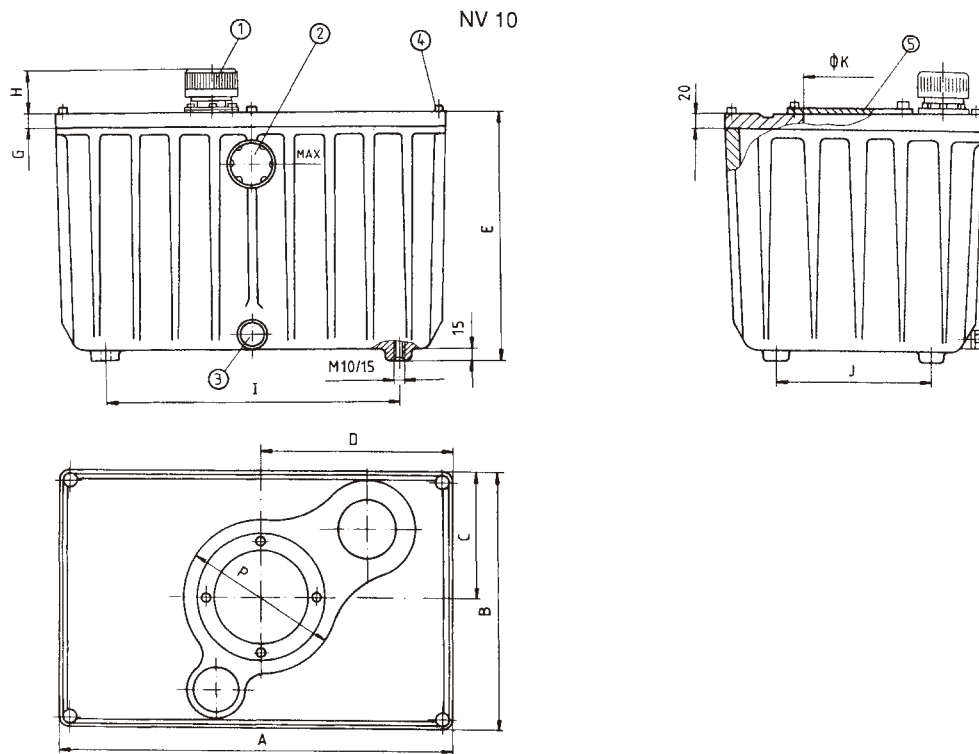

Nazivna zapremina Nominal volume (l)	A	B	C	D	E	G	H	I	J	K	P
10	320	270	112	208	250	19	63	254	204	80	160
16	450	350	130	140	260	22	63	320	320	-	200
25	550	380	140	160	315	22	63	400	400	-	200
40	600	400	140	170	390	22	63	450	450	-	250
63	600	400	140	170	520	22	63	450	450	-	250

- ① Nalivni filter sa oduškom Filling filter with breather
 ② Pokazivač nivoa Level gauge
 ③ Čep M22x1,5 plug M22x1,5
 ④ Vijak M10 Bolt M10
 ⑤ Poklopac Cover